

John N. Ward  
Vice President, Marketing & Government Affairs  
Headwaters Incorporated

Testimony  
Before the Subcommittee on Energy and Environment  
Committee on Science and Technology  
United States House of Representatives

The Benefits and Challenges of Producing Liquid Fuel from Coal:  
The Role for Federal Research  
September 5, 2007

### **Improving America's Energy Security Through Liquid Fuels Derived from Coal**

Thank you Mr. Chairman. Honorable Members of the Committee, I am John Ward, Vice President of Headwaters Incorporated, on whose behalf I am testifying today. I also serve as Immediate Past President of the American Coal Council and as a member of the National Coal Council as appointed by the Secretary of Energy.

Headwaters Incorporated is a New York Stock Exchange company that provides an array of energy services. We are a leading provider of pre-combustion clean coal technologies for power generation, including coal cleaning, upgrading and treatment. We are the nation's largest post-combustion coal product manager, recycling coal ash from more than 100 power plants nationwide. We have built a large construction materials manufacturing business and incorporated coal ash in many of our products. We are currently commercializing technologies for upgrading heavy oil and have entered the biofuels market by constructing our first ethanol production facility utilizing waste heat from an existing coal fueled power plant in North Dakota. Headwaters is also active as both a technology provider and a project developer in the field of coal-to-liquid fuels.

Headwaters is a member of the Coal-to-Liquids Coalition -- a broad group of industry, labor, energy technology developers and consumer groups. This coalition is interested in strengthening U.S. energy independence through greater utilization of domestic coal to produce clean transportation fuels.

#### **Summary of Testimony**

The prospect of making liquid transportation fuels from America's abundant coal resources has received significant attention in recent months. As with any high profile policy debate, this means that many misconceptions have arisen. It may be best, at this point, to summarize what "Coal-to-Liquids" is by pointing out what it is not:

- Coal-to-liquids is not a new kind of fuel. Any liquid fuel product that can be made from crude oil can be made from coal. Products from coal-to-liquids plants include high quality gasoline, diesel fuel, and jet fuel that can be used in existing engines without making any modifications to the engines or distribution systems for the fuel.
- Coal-to-liquids is not dirty. In fact, fuels produced by coal-to-liquids processes are exceptionally clean when compared to today's petroleum-derived transportation fuels. Coal-to-liquids fuels contain substantially no sulfur and also exhibit lower particulate and carbon monoxide emissions. These fuels also contribute less to the formation of nitrogen oxides than petroleum derived fuels and they are readily biodegradable. As for greenhouse gas emissions, coal-to-liquids refineries generate carbon dioxide in highly concentrated form allowing carbon capture and storage. Coal-to-liquids refineries with carbon dioxide capture and storage can produce fuels with life-cycle greenhouse gas emission profiles that are as good as or better than that of the petroleum-derived products they replace.
- Coal-to-liquids is not strictly a research and development effort. The term "coal-to-liquids" refers to a broad class of technologies for making liquid transportation fuels from coal. Many of these technologies have been known for decades and many are being deployed at commercial scale around the world. Likewise, carbon capture and storage technologies are currently being practiced at commercial scale for enhanced oil recovery operations.

As the federal government considers measures to support coal-to-liquids, it is important to provide two different types of support:

- Commercialization incentives are needed to speed the commercial deployment of coal-to-liquids facilities in the United States with the goal of increasing our nation's energy security.
- Research support is needed to continue to improve the efficiency and environmental performance of coal-to-liquids technologies with the goal of making this already clean resource even cleaner.

Specific areas where continued research and development support would be beneficial include:

- Utilization of biomass as a strategy for reducing greenhouse gas emissions.
- Improving life cycle assessment tools for determining greenhouse gas emissions profiles for coal-to-liquids facilities when compared to other fossil fuel energy sources.

- Expanding methods of carbon capture and storage beyond currently available opportunities in the area of enhanced oil recovery.

### **Why Coal-to-Liquids?**

It's easy to see why coal-to-liquids is attracting so much attention these days. In the president's words, the United States is addicted to oil. U.S. petroleum imports in 2005 exceeded \$250 billion. In the past two years, natural disasters have disrupted oil production and refining on the U.S. gulf coast. Political instability in the Middle East and other oil producing regions is a constant threat. Fuel prices have rapidly escalated along with world oil prices that are reaching levels unseen since the 1970s energy crisis.

The situation is not likely to get much better in the future. Global oil demand was 84.3 million barrels per day in 2005. The United States consumed 20.7 million barrels per day (24.5%) and imported 13.5 million barrels per day of petroleum products. Worldwide demand for petroleum products is expected to increase 40% by 2025 largely due to growing demand in China and India. World oil production could peak before 2025. Most of the remaining conventional world oil reserves are located in politically unstable countries.

In contrast, coal remains the most abundant fossil fuel in the world and the United States has more coal reserves than any other country. With coal-to-liquids technology, the United States can take control of its energy destiny. Any product made from oil can be made from coal. At today's oil prices, coal-to-liquids is economical and has the power to enhance energy security, create jobs here at home, lessen the U.S trade deficit, and provide environmentally superior fuels that work in today's vehicles. By building even a few coal-to-liquids plants, the U.S. would increase and diversify its domestic production and refining base – adding spare capacity to provide a shock absorber for price volatility.

### **Coal-to-Liquids Historical Perspective**

Headwaters and its predecessors have been engaged in coal-to-liquids technologies since the late 1940s. Our alternative fuels division is comprised of the former research and development arm of Husky Oil and holds approximately two dozen patents and patents pending related to coal-to-liquids technologies.

The founders of this group included scientists engaged in the Manhattan Project during World War II. After the conclusion of the war, these scientists were dispatched to Europe to gather information on technologies used by Germany to make gasoline and diesel fuel from coal during the war.

In the late 1940s, this group designed the first high temperature Fischer Tropsch conversion plant which operated from 1950 to 1955 in Brownsville, Texas. It produced liquid fuels commercially at a rate of 7,000 barrels per day. Why did it shut down? The discovery of cheap oil in Saudi Arabia.

The Arab oil embargo of 1973 reignited interest in using domestic energy resources such as coal for producing transportation fuels. From 1975 to 2000, Headwaters researchers were prime developers of direct coal liquefaction technology. This effort, which received more than \$3 billion of federal research funding, led to the completion of an 1,800 barrels per day demonstration plant in Catlettsburg, Kentucky. Why did deployment activities cease there? OPEC drove oil prices to lows that left new technologies unable to enter the market and compete.

Today, our nation finds itself in another energy crisis. Oil costs more than \$70 per barrel and comes predominantly from unstable parts of the world. There is little spare production and refining capacity and our refineries are concentrated in areas susceptible to natural disasters or terrorist attacks. And once again, our nation is considering coal as a source for liquid transportation fuels. The question is: What can we do this time to ensure that the technologies are fully deployed?

### **Coal-to-Liquids Technology Overview**

From a product perspective, coal-to-liquids refineries are very similar to petroleum refineries. They make the same range of products, including gasoline, diesel fuel, jet fuel and chemical feedstocks. These fuels can be distributed in today's pipelines without modification. They can be blended with petroleum derived fuels if desired. They can be used directly in today's cars, trucks, trains and airplanes without modifications to the engines.

From a production perspective, coal-to-liquids refineries utilize technologies that have been commercially proven and are already being deployed in other parts of the world. Two main types of coal-to-liquids technologies exist. Indirect coal liquefaction first gasifies the solid coal and then converts the gas into liquid fuels. Direct coal liquefaction converts solid coal directly into a liquid "syncrude" that can then be further refined into fuel products.

To understand how coal-to-liquids technologies work, it is helpful to focus on the role of hydrogen in fuels. Coal typically contains only 5% hydrogen, while distillable liquid fuels such as petroleum typically contain 14% hydrogen. The hydrogen deficit can be made up in two different ways:

Direct Coal Liquefaction (DCL)

Coal + Catalyst + Hydrogen ( $H_2$ )  $\rightarrow$  Hydrocarbons ( $C_xH_y$ )

or

Indirect Coal Liquefaction (ICL)

1. Gasification: Coal + Oxygen + Steam  $\rightarrow$  Syngas ( $H_2 + CO$ )
2. FT Synthesis:  $H_2 + CO + Catalyst \rightarrow$  Hydrocarbons ( $C_xH_y$ )

### Direct Coal Liquefaction

Direct coal liquefaction involves mixing dry, pulverized coal with recycled process oil and heating the mixture under pressure in the presence of a catalyst and hydrogen. Under these conditions, the coal transforms into a liquid. The large coal molecules (containing hundreds or thousands of atoms) are broken down into smaller molecules (containing dozens of atoms). Hydrogen attaches to the broken ends of the molecules, resulting in hydrogen content similar to that of petroleum. The process simultaneously removes sulfur, nitrogen and ash, resulting in a synthetic crude oil (syncrude) which can be refined just like petroleum-derived crude oil into a wide range of ultra-clean finished products.

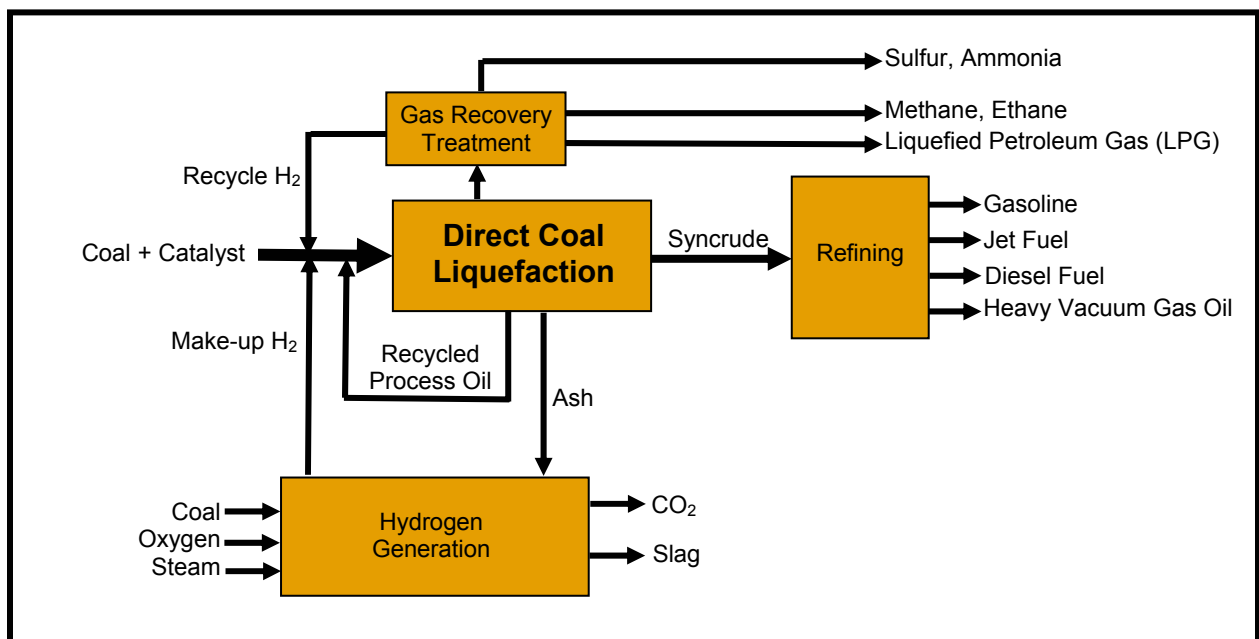

DCL Process Block Flow Diagram

Direct coal liquefaction originated in Germany in 1913, based on work by Friedrich Bergius. It was used extensively by the Germans in World War II to produce high octane aviation fuel. Since that time, tremendous advancements have been made in product yields, purity and ease of product upgrading.

From 1976 to 2000, the US government invested approximately \$3.6 billion (1999 dollars) on improving and scaling up direct coal liquefaction. During this time, pilot and demonstration facilities ranging from 30 to 1800 barrels per day of liquid fuel were built and operated in the United States. The end result of this effort is the HTI DCL process developed by Hydrocarbon Technologies Incorporated, a subsidiary of Headwaters.

In June 2002, the largest coal company in China (Shenhua Group) agreed to apply the HTI technology for the first phase of a three-phase multi-billion dollar direct coal liquefaction project. The Shenhua direct coal liquefaction facility in Inner Mongolia is

currently under construction and is scheduled to startup in 2008. The first phase, as currently configured, has a capacity of 20,000 barrels per day.

Additional direct coal liquefaction projects are currently being studied or planned in India, the Philippines, Mongolia and Indonesia. The Philippines project is based on hybrid technology utilizing both direct and indirect coal liquefaction.

### *Indirect Coal Liquefaction*

Indirect coal liquefaction is a two-step process consisting of coal gasification and Fischer-Tropsch (FT) synthesis. Coal is gasified with oxygen and steam to produce a synthesis gas (syngas) containing hydrogen and carbon monoxide. The raw syngas is cooled and cleaned of carbon dioxide and impurities. In the FT synthesis reactor, the cleaned syngas comes in contact with a catalyst that transforms the diatomic hydrogen and carbon monoxide molecules into long-chained hydrocarbons (containing dozens of atoms). The FT products can be refined just like petroleum-derived crude oil into a wide range of ultra-clean finished products.

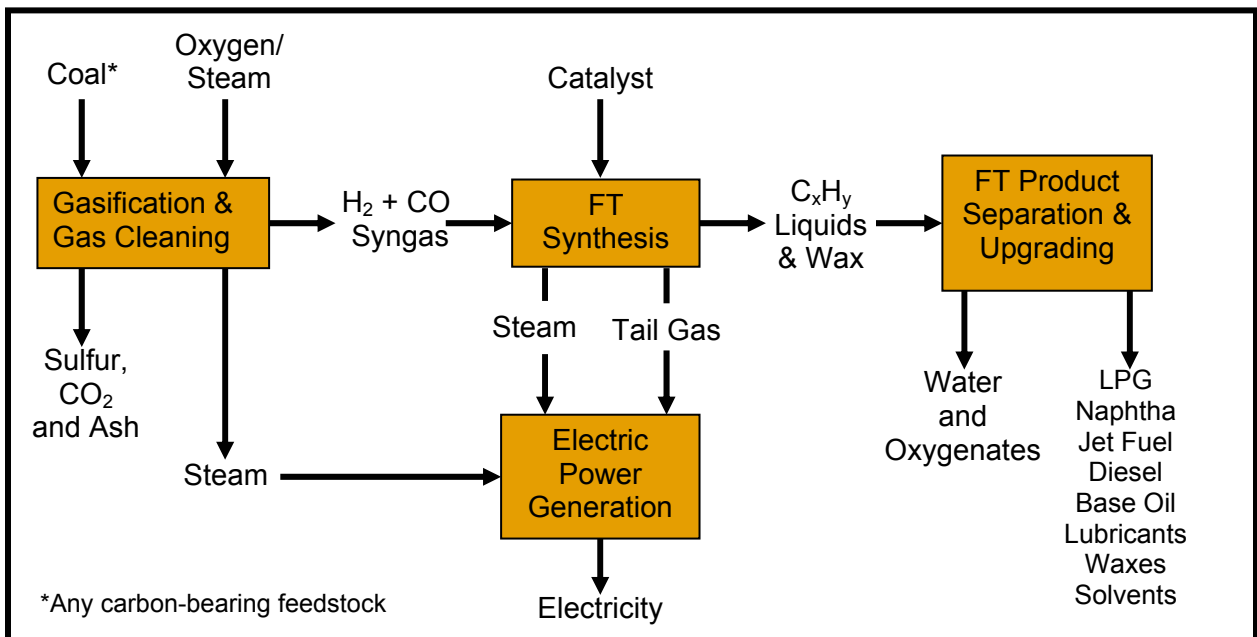

ICL Process Block Flow diagram

Indirect coal liquefaction was developed in Germany in 1923 based on work by Drs. Franz Fischer and Hans Tropsch. During World War II, the technology was used by Germany to produce 17,000 barrels per day of liquid fuels from coal.

In 1955, Sasol constructed an indirect coal liquefaction plant at Sasolburg, South Africa. Additional indirect coal liquefaction plants were constructed by Sasol in Secunda, South Africa. Today Sasol produces the equivalent of 150,000 barrels per day of fuels and petrochemicals using its technology – supplying approximately 30% of South Africa's

liquid transportation fuels from coal. Technologies for indirect coal liquefaction are also being developed and deployed by Headwaters, Shell, Syntroleum and Rentech.

Indirect coal liquefaction projects are currently being studied or planned in China, Philippines, Germany, Netherlands, India, Indonesia, Australia, Mongolia, Pakistan and Canada. In the United States, indirect coal liquefaction projects are being considered in Alaska, Arizona, Colorado, Illinois, Indiana, Kentucky, Louisiana, Mississippi, Montana, North Dakota, Ohio, Pennsylvania, Texas, West Virginia and Wyoming,

#### *Comparison of Direct and Indirect Coal Liquefaction Products*

One of the main differences between direct and indirect coal liquefaction is the quality of the raw liquid products. Direct coal liquefaction raw products contain more ring structure. Therefore direct coal liquefaction naphtha is an excellent feedstock for production of high-octane gasoline, while direct liquefaction distillate requires considerable ring opening (mild hydrocracking) to generate on spec diesel fuel. On the other hand, the straight-chain structure hydrocarbons produced by indirect coal liquefaction technology results in high-cetane diesel fuel, but indirect liquefaction naphtha needs substantial refining (isomerization and alkylation) to produce on spec gasoline.

Both processes produce low-sulfur, low-aromatic fuels after the refining step. Direct and indirect coal liquefaction can be combined into a hybrid plant that produces both types of products that can be blended into premium quality gasoline, jet fuel and diesel with minimum refining.

|                          | <b>Direct</b>             | <b>Indirect</b>                  | <b>EPA 2006 Diesel Spec</b> |
|--------------------------|---------------------------|----------------------------------|-----------------------------|
| Distillable product mix  | 65% diesel<br>35% naphtha | 65 -80% diesel<br>20-35% naphtha |                             |
| Diesel cetane            | 42-47                     | 70-75                            | >40                         |
| Diesel sulfur            | <5 ppm                    | <1 ppm                           | <15 ppm                     |
| Diesel aromatics         | 4.8%                      | <4%                              | <35%                        |
| Diesel specific gravity  | 0.865                     | 0.780                            |                             |
| Naphtha octane (RON)     | >100                      | 45-75                            |                             |
| Naphtha sulfur           | <0.5 ppm                  | Nil                              |                             |
| Naphtha aromatics        | 5%                        | 2%                               |                             |
| Naphtha specific gravity | 0.764                     | 0.673                            |                             |

Indirect coal liquefaction plants usually include combined-cycle electric power plants because they produce a substantial amount of steam and fuel gas that can be used to generate electricity. Direct coal liquefaction plants produce less steam and fuel gas, so they can be designed to purchase electricity, be self-sufficient in electricity generation or generate excess power depending on the local market conditions.

Direct coal liquefaction plants produce more liquid fuel per ton of coal than indirect plants. However, indirect plants are better suited for polygeneration of fuels, chemicals and electricity than direct plants.

The preferred feedstock for direct coal liquefaction plants is low-ash, sulfur-bearing, sub-bituminous or bituminous coal. Indirect plants have greater feedstock flexibility and can be designed for almost any type of coal ranging from lignite to anthracite.

### **Coal-to-Liquids Environmental Profile**

Fuels produced by coal-to-liquids processes are usable in existing engines without modifications and can be distributed through existing pipelines and distribution systems. Nevertheless, they are exceptionally clean when compared to today's petroleum-derived transportation fuels.

Indirect coal liquefaction fuels derived from the Fischer-Tropsch process, in particular, contain substantially no sulfur and also exhibit lower particulate and carbon monoxide emissions. These fuels also contribute less to the formation of nitrogen oxides than petroleum derived fuels and they are readily biodegradable.

The production of coal-to-liquids fuels is also environmentally responsible. Because coal liquefaction processes remove contaminants from coal prior to combustion, process emissions from coal-to-liquids plants are much lower than traditional pulverized coal power plants.

Both direct and indirect coal liquefaction plants generate carbon dioxide in highly concentrated form allowing carbon capture and storage. Coal-to-liquids plants with carbon dioxide capture and storage can produce fuels with life-cycle greenhouse gas emission profiles that are as good as or better than that of petroleum-derived products.

A life-cycle greenhouse gas emissions inventory for indirect coal liquefaction diesel was prepared for the U.S. Department of Energy National Energy Laboratory (NETL) in June 2001. This study compared the emissions for indirect coal liquefaction (with and without carbon capture and storage) diesel with conventional petroleum diesel delivered to Chicago, IL. Some of the results from that study are summarized in the following table:

| <b>Feedstock</b>                  | <b>Grams of CO<sub>2</sub>-equivalent Emissions per Mile in a Sport Utility Vehicle</b> |                                 |   |                               |                                 |
|-----------------------------------|---|---------------------------------|---|-------------------------------|---------------------------------|
|                                   | <b>Extraction/<br/>Production</b>   | <b>Conversion/<br/>Refining</b> | <b>Transportation/<br/>Distribution</b> | <b>End Use<br/>Combustion</b> | <b>Total<br/>Fuel<br/>Chain</b> |
| IL#6 Coal<br>(ICL without<br>CCS) | 26  | 543                             | 1                                       | 368                           | 939                             |
| IL#6 Coal<br>(ICL with CCS)       | 26  | 94                              | 1                                       | 368                           | 490                             |

|                      |    |     |    |     |     |
|----------------------|----|-----|----|-----|-----|
| WY Sweet Crude Oil   | 23 | 74  | 8  | 363 | 468 |
| Arab Light Crude Oil | 35 | 81  | 26 | 367 | 509 |
| Alberta Syncrude     | 32 | 104 | 10 | 370 | 516 |

Life-cycle greenhouse gas emission inventories have not been completed on direct and hybrid coal liquefaction technologies. However, based on the fact that these technologies have lower plant CO<sub>2</sub> emissions than indirect coal liquefaction and the CO<sub>2</sub> is in concentrated form, it can be assumed that direct and hybrid technologies will have lower life-cycle GHG emissions than conventional petroleum diesel.

Gasification technologies like those that would be used in coal-to-liquids plants have already demonstrated the ability to capture and store carbon dioxide on a large scale. For example, the Dakota Gasification facility in North Dakota captures CO<sub>2</sub> from the gasification process and transports it by pipeline to western Canadian oil fields where it is productively used for enhanced oil recovery.

There is also growing interest in utilizing coal and biomass (agricultural and forestry by-products) together to further reduce net carbon dioxide emissions. This is achieved because biomass is considered a renewable resource and a zero net carbon dioxide emitter. The co-processing of coal and biomass would allow a much greater scale of liquid fuel production than an exclusive reliance on biofuels.

The co-processing of coal and biomass in commercial gasification plants is being done in Europe in the range of 80 to 90 percent coal and 10 to 20 percent biomass. It is speculated that up to 30 percent of the feed mix could be in the form of biomass; however there are economic and logistic issues to consider. Biomass is a bulky material with low density, high water content and is expensive to transport and pre-process for gasification. In addition, it tends to be seasonal and widely dispersed.

### **Coal-to-Liquids Economics Profile**

Coal-to-liquids projects are capital intensive. Direct coal liquefaction is slightly less capital intensive than indirect coal liquefaction (\$50,000-\$60,000/bpd versus \$60,000-\$80,000/bpd). Escalating capital costs related to raw materials prices and equipment availability make small coal-to-liquids projects less economic and may force some developers to look at larger capacity projects on the order of 30,000 to 80,000 barrels per day to take advantage of economies of scale.

High capital costs (\$2.5 billion to \$6 billion per project) and large project size (30,000 to 80,000 barrels per day) will dictate where and how viable coal-to-liquids projects can be built. Multiple partners will likely be required to spread the risks and costs. These partners may include coal suppliers, technology providers, product users, operators, or private equity providers.

Large, low-cost coal reserves (from 500 million tons to over 1 billion tons) will be needed; preferably dedicated to the project. Coal-to-liquids plants can be adapted to handle any kind of coal through proper selection of the coal gasification technology.

The following graph indicates the impact of plant size on project economics. Large CTL plants (30,000 to 80,000 barrels per day) can compete with petroleum-derived products when crude oil prices exceed \$35 to \$45 per barrel, not including costs related to carbon capture and storage. In this case the debt to equity ratio was assumed to be 70:30 and did not include any government incentives on product sales. This graph is only for discussion purposes. Economic analysis should be based on site specific conditions for each project.

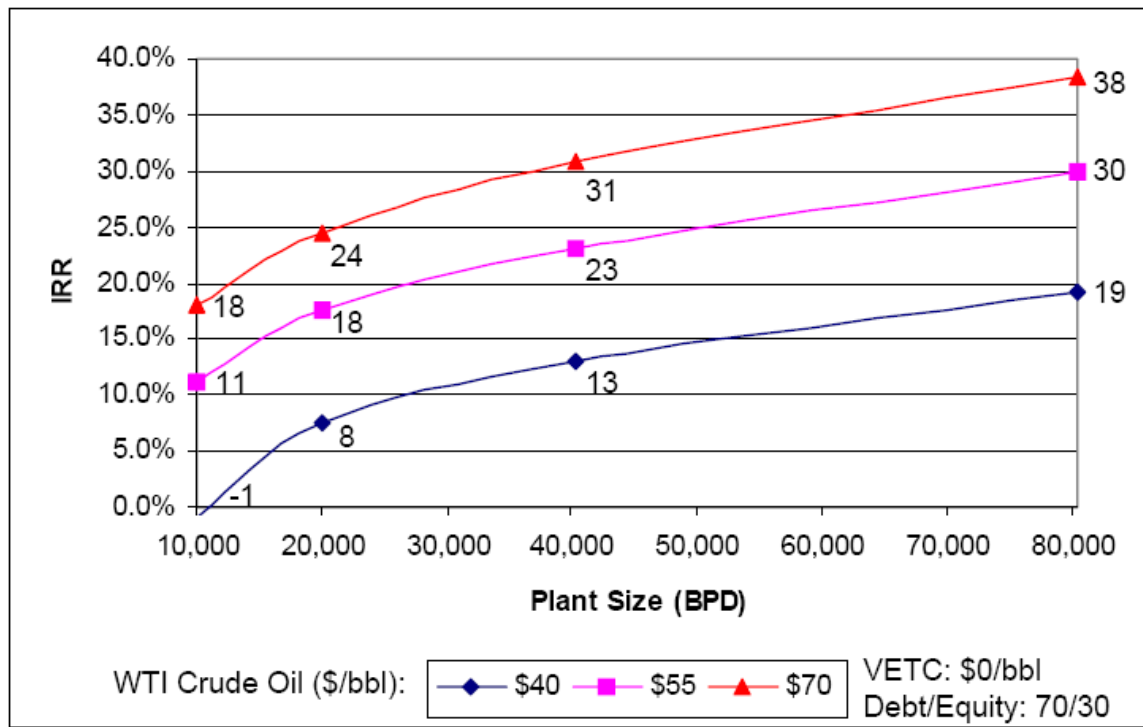

### Coal-to-Liquids Commercialization Challenges

Estimates of the potential for coal-to-liquids vary widely. The Southern States Energy Board that posits the possibility of coal-to-liquids production exceeding 5 million barrels per day. The National Coal Council puts forth the vision of 2.6 million barrels per day by the year 2030. The Energy Information Administration reference case forecast projects coal-to-liquids production at about 800,000 barrels per day by 2030. This forecast assumes real oil prices increase 1.6 percent per annum over the forecast period. If real prices rise 3.6 percent per annum, EIA projects coal-to-liquids production to more than double to over 1.6 million barrels per day.

Although larger scale coal-to-liquids projects appear to be economically viable in today's oil price environment, there are still significant hurdles to get the first projects built. There are no coal-to-liquids plants operating in the U.S. that would serve as commercially proven models. Until that happens, financial institutions will be reluctant to

fund multi-billion dollar projects without significant technology and market performance guarantees. This includes some assurance that plants will not be rendered uneconomic by oil producing nations or cartels that may seek to artificially reduce oil prices just long enough to prevent the formation of this competitive new industry.

Other nations are moving forward more aggressively to deploy coal-to-liquids technologies. In China, for instance, the government has already committed more than \$30 billion to commercialization of coal gasification and liquefaction technologies and construction of the first plants has begun.

In the United States, Headwaters is one of several companies that are pursuing development of coal-to-liquids projects using private sector financing. As an example, one of the projects we are pursuing in the United States is the American Lignite Energy project located in North Dakota. American Lignite Energy features ample coal reserves, highly qualified development partners, and substantial existing infrastructure to support the facility. The State of North Dakota has been exceptionally supportive and has already committed \$10 million of matching funds for front end engineering and design activities. But the project's viability is by no means certain. The task of raising upwards of \$2 billion to build one of the first American coal-to-liquids refineries is daunting – especially for smaller companies like ours.

Headwaters certainly does not advocate abandoning America's open and efficient financial markets for a more centralized system like China's. But the United States should recognize that just because a technology is no longer a research project does not mean that the free market is ready to fully embrace it.

As long as oil prices remain high or climb higher, market forces will lead to the development of a coal-to-liquids infrastructure in the United States. But that development will come slowly and in measured steps. If for energy security reasons, the United States would like to speed development of a capability for making transportation fuels from our most abundant domestic energy resource, then incentives for the first coal-to-liquids project are appropriate.

### **Coal-to-Liquids Potential Commercialization Incentives**

Incentives for commercializing coal-to-liquids technologies in the United States should be constructed to address the market risks that make financing of the first several plants difficult. For example, one widely discussed approach would establish an "oil price collar" to guide the government's investment. If oil prices were to drop below a specified level, the United States would make payments to coal-to-liquids projects participating in the program to ensure their viability. Alternatively, if oil prices rose above a higher specified level, the participating projects would pay back into the program. Properly constructed, such a program could have a meaningful effect on addressing the market risk associated with fluctuating oil prices.

The Coal-to-Liquids Coalition has also identified five specific actions the federal government could take to help overcome deployment barriers:

1. Provide funding, through non-recourse loans or grants, for Front End Engineering and Design (FEED) activities. These activities are necessary to define projects sufficiently to seek project financing in the private sector. FEED for a billion dollar project can cost upwards of \$50 million.
2. Provide markets for the fuel produced by the first coal-to-liquids plants. Federal agencies like the Department of Defense are major consumers of liquid fuels. By agreeing to purchase coal derived fuels at market value, but not lower than a prescribed minimum price, the government can remove the risk of reductions in oil prices that could stop development of this industry.
3. Extend excise tax credit treatment for coal derived fuels. The recent SAFETEA-LU Bill extended to coal-derived fuels the approximately 50 cents per gallon excise tax credit that was originally created as an incentive for ethanol production. But the provision as now enacted will expire before any coal-to-liquids facilities could be placed in service.
4. Appropriate funds for loan guarantees authorized in the Energy Policy Act of 2005 and ensure that those funds are made available to coal-to-liquids projects.
5. Ensure that industrial gasification tax credits authorized in the Energy Policy Act of 2005 are also extended to coal-to-liquids projects.

Combined with support from states and local communities anxious to see development of coal resources, these actions would help private industry bridge the deployment gap and establish a coal-to-liquids capability more quickly for our nation.

### **Areas Needing Additional Research and Development**

Research support is needed to continue to improve the efficiency and environmental performance of coal-to-liquids technologies with the goal of making this resource even cleaner.

Headwaters has for a period of over 25 years collaborated with DOE's National Energy Technology Laboratory (NETL) on a number of research and development activities related to the direct and indirect conversion of coal to transportation fuels and chemicals.

Most recently, we have benefited from a number of economic and technical reports and analyses on coal conversion processes that have been both created and made public by NETL. Particularly pertinent to today's discussion is a recently completed study for the Air Force, showing how coal biomass to liquids (CBTL) processes can be economically and environmentally competitive, not only in today's marketplace, but also in the future when the control of greenhouse gases becomes a national mandate.

Specific areas where continued research and development support would be beneficial include:

- Utilization of biomass as a strategy for reducing greenhouse gas emissions.
- Improving life cycle assessment tools for determining greenhouse gas emissions profiles for coal-to-liquids facilities when compared to other fossil fuel energy sources.
- Expanding methods of carbon capture and storage beyond currently available opportunities in the area of enhanced oil recovery.

### **Coal-to-Liquids Advantages**

The advantages to developing a coal-to-liquids capability in the United States are numerous. Some of the dollars we now send overseas to buy oil would be kept at home to develop American jobs utilizing American energy resources. We would expand and diversify our liquid fuels production and refining capacity using technologies that are already proven. We would produce clean-burning fuels that can be distributed through our existing pipelines and service stations to fuel our existing vehicles with no modifications to their engines. We would take a real and immediate step toward greater energy security.

Thank you for the invitation to testify and for your interest in this important topic. I would be happy to answer any questions.